

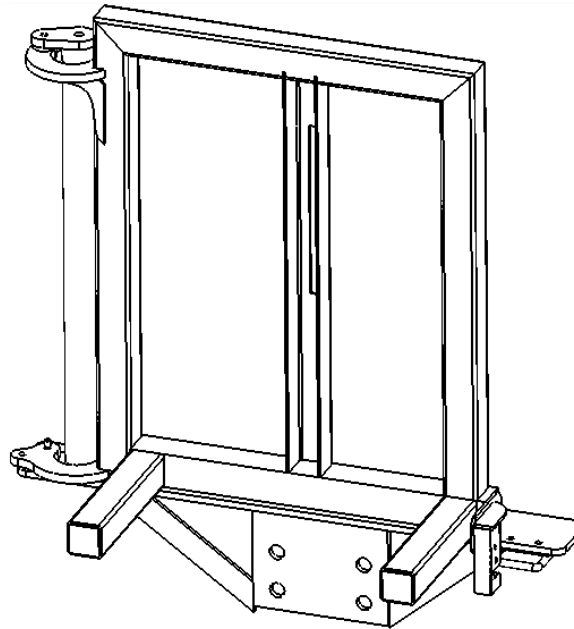

1992-2014 FORD VAN REAR TIRE CARRIER
INSTALLATION INSTRUCTIONS
PN# 210726



Please read before beginning

- *Stainless steel hardware may bind together when tightening—It is recommended that you apply an anti-seize assembly lubricant to the threads of each bolt before assembly.*
- *This installation requires two people*
- *This tire rack will not fit with vehicles that have a body lift. Please contact Aluminess for options if your van is equipped with a body lift.*
- *This tire rack is set up for wheel/tire combos with 5.75" backspacing (including tire bulge). If you have something different, please contact Aluminess for options.*
- *Unless otherwise specified, refer to the general torque value at the end of the instructions for specified torque values.*

Required tools

- *Drill and drill bits (1/4", 5/16", 3/8")*
- *Standard wrench set*
- *Hammer and punch*

Included hardware

Quantity

70019 – 5/16-18 Nylock Nuts SS	1
70027 – 3/8 x 7/8 Washer Flat SS	8
70029 – Bolt, Hex Head, SS, 3/8-16 x 1-1/4"	1
70024 - Nut, Nylock, SS, 3/8-16	2
70255 – Pin Lock , ss , 3/8 x 1 3/4	1
70478 – Bolt, 1/4"-20 x 1/2", Tamper Resistant, SS	4
70479 – 5/32", Tamper Resistant, Hex Bit	1
401132 – 1/4" Hex Bit Holder, Key Chain	1
70480 – 3/8"-16 x 5" Fully Threaded, Hex Head, Zinc	1
70271 – 3/8" ID Tooth, Lock Washer, Zinc	1
70348 – 3/8" – 16 x 1.25" , Carriage Bolt, SS	2
70246 – Antiseize bolt lubricant packet, 2g	1



Included Parts/Subassemblies

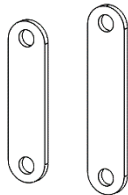

**x1 (short)
x 1 (long)**
Straps, Ford Van
350175 & 350175.1



x1
Door Pin Assy,
Ford Van
350177



x 1
70255 Pin
Lock,SS 3/8 x 1
3/4X1

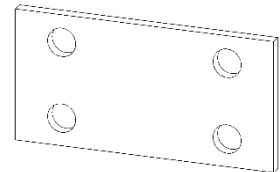

x 1
300199 Spacer
Plate, Ford Van,
Tire Rack

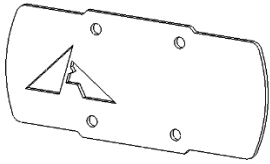

301620 – Universal
Tire Mount Wheel
Wedge Cover
QTY : 1

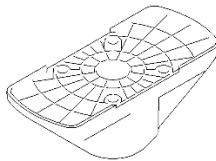

301629 – Universal
Tire Mount Wheel
Wedge
QTY : 1

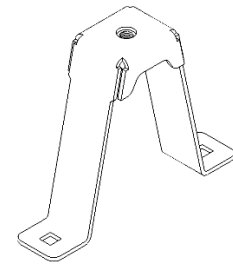

351133– Universal Tire
Mount, Bracket
QTY : 1

Assembly instructions

1. Remove the nuts on the driver side existing rear bumper
2. Loosen the passenger side nuts
3. Before installing the tire rack you will need to remove the upper door hinge pin on the driver side door
 - a. Tape a piece of cardboard below the hinge to protect the paint on the van
 - b. Drill the bottom of the hinge pin with a 3/8" drill bit 1/4" up into the hinge
 - c. Use a hammer and punch to drive the pin out of the hinge. The pin is splined at the top and requires hard blows to remove. A heavy hammer or 3 lb sledge is best. You will be attaching the stainless-steel strap to the hinge bolt
 - d. With the stock hinge pin removed, close the van door tightly.
4. Remove the nuts from the driver side bumper and set the Aluminess tire rack between the bumper and frame mount.
5. Re-insert the bolts on the bumper through the holes and tighten the bolts down about half way.
6. Adjust the tire rack so it is level. Do not tighten until the strap is secured.



7. Place one of the two straps onto the exposed hole on the tire rack, and the exposed hinge on the van door to see which length of strap you need. Keep in mind that the tire rack has some adjustment left to right if the strap seems to just too long or just too short.
8. Once you have selected the appropriate strap, use the hinge bolt we provided and put the hinge bolt thru the washer, then through the strap, then through the open hinge on the van door, second washer, and place the nylock nut on the bottom of the hinge pin.
9. Tighten the new door hinge pin down and adjust the tire rack up and down left and right so that the strap reaches the exposed hole on top of the pole, and then tighten down the tire rack to the frame of the vehicle.
10. Put the 3/8" bolt through a washer, then the strap, then another washer, and then thread it into the top of the pole.
11. Remove the nuts on the passenger side of the bumper and insert the spacer to keep the bumper even (parallel to the van).
12. Tighten the mounting bolts but make sure that the swing arm is level.
13. The tire rack is now installed—check the mounting hardware after 100 miles of driving to ensure that nothing has come loose due to vibration.

Tire Installation Instructions

1. Loosely fasten the Tire Mount Bracket to the slotted channel, going through the bracket first, using the 3/8" carriage head bolts, washer, and nuts to mount. Reference Figure 1.

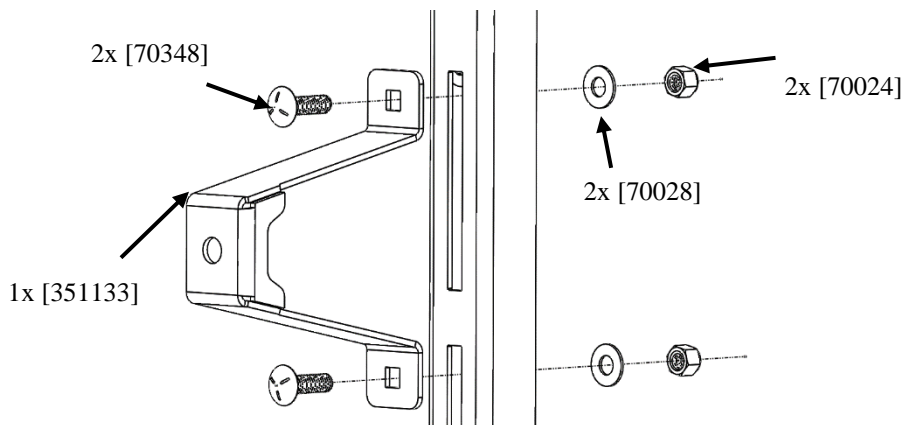

Figure 1: Mounting Tire Bracket

2. Place the mounting bracket in the correct location by placing your tire on the tire supports and then adjusting the bracket vertically until the center hub aligns with the center of the bracket.
3. Once the bracket is in place remove the tire and tighten the hardware holding the bracket in place.
4. Place the tire on the support stands and mount the wheel wedge, using the 5" hex head bolt, washer and star washer. Reference Figure 4 and 5.

NOTE: Tighten down bolt until snug with wedge (it should be very hard/near impossible to rotate the wedge by hand. Once at this point tighten 2 more full rotations.

Note: preferred torque spec is 45 inch pounds .

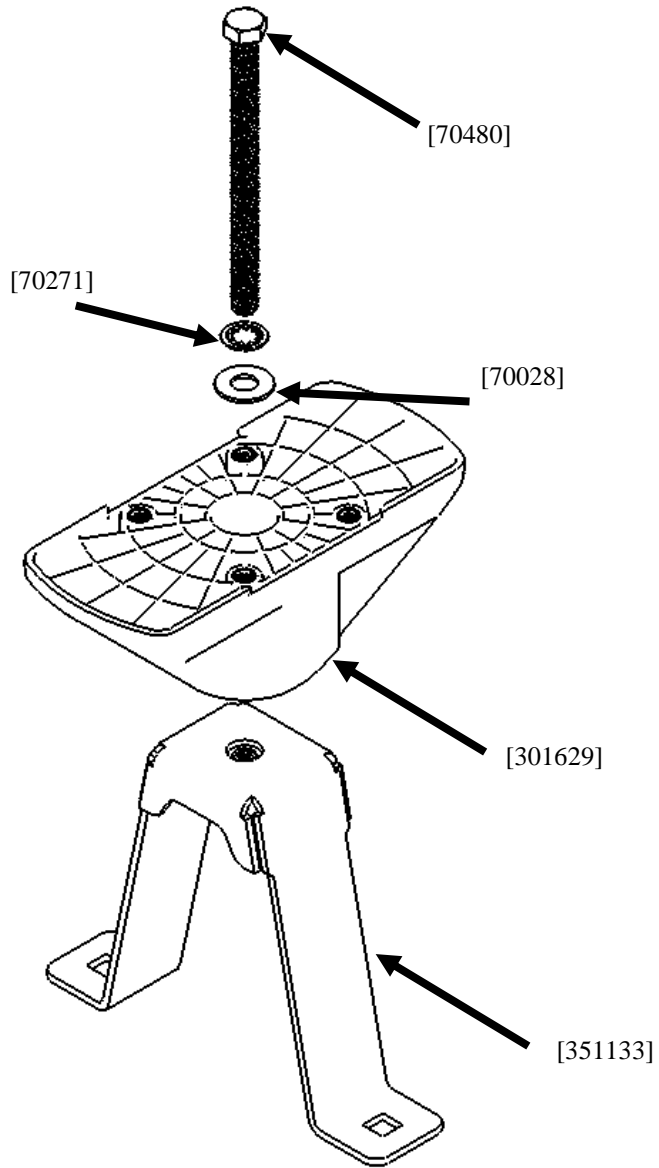

Figure 4: Wheel Wedge Assembly



Figure 5: Tire Mount Assembled

5. [Optional] If desired, you can mount a Rotopax to the wheel wedge. After installing the cover [Step 6], bolt the rotopax mount through the wheel wedge cover to the wheel wedge using the security bolts [70478], as shown below in figure 6. Then simply install the rotopax onto the mount.



Figure 6: Rotopax Mount



- Once everything is securely fastened, bolt the cover to the wheel wedge using the included special bit [70479], and bolts [70478]. Reference Figure 7.

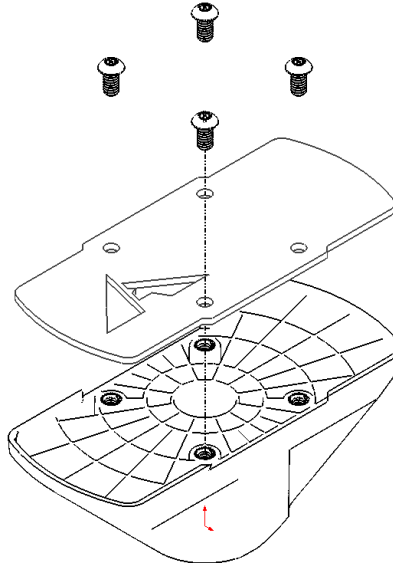

Figure 7: Wheel Wedge, Cover Mounting

General Torque Values			
Size	Stainless Steel	Zinc	Grade 8
#6-32	10 lb-ft	--	--
#8-32	18.4 lb-ft	--	--
#10-32	26.6 lb-ft	--	--
1/4"-20	5.3 lb-ft	7.8 lb-ft	9 lb-ft
5/16"-18	10.9 lb-ft	16 lb-ft	18 lb-ft
3/8"-16	19.4 lb-ft	28.3 lb-ft	33 lb-ft
7/16"-14	31 lb-ft	45 lb-ft	52 lb-ft
1/2"-13	47 lb-ft	69 lb-ft	80 lb-ft
M6	4.7 lb-ft	5.8 lb-ft	--
M8	11.3 lb-ft	14.1 lb-ft	--
M10	22.3 lb-ft	27.9 lb-ft	--
M12	38.9 lb-ft	48.7 lb-ft	--



Aluminess Products, Inc. (Aluminess) Warranty

1. Lifetime Warranty. Aluminess provides a lifetime warranty of its products to the original retail purchaser provided such products are installed correctly according to the official Aluminess installation instructions. Any modification to the original product design, function or use of any Aluminess products will void the Aluminess warranty. Aluminess will have sole discretion to determine warranty eligibility for any and all Aluminess products sold to any purchaser.
2. Limited Remedies. Subject to any limitations and exclusions described herein, and subject to Aluminess' determination of warranty eligibility, Aluminess will remedy defects in product materials and/or workmanship of any product by repairing or replacing such defective product, which shall be within Aluminess' sole discretion, without charge for parts or labor. Aluminess may elect in its sole discretion not to replace a defective product and issue the purchaser a refund equal to the purchase price of any defective product or purchaser may elect to receive a credit (equal to such refund) toward the purchase of new Aluminess products. Repair or replacement of a defective product or providing a refund or credit to purchaser will be purchaser's exclusive remedy under this warranty. Damage to a purchaser's vehicle, cargo and/or any other person or property is expressly excluded from the Aluminess warranty.
3. Modification. Aluminess products are designed to be mounted to factory equipped vehicles. Aftermarket additions to such vehicle may or may not require modification of an Aluminess product. The Aluminess warranty does not extend to any Aluminess products that are modified to fit around other otherwise accommodate or be compatible with any aftermarket vehicle accessories or alterations. Aluminess does not guarantee fitment with any other aftermarket accessories or modified vehicle, and it is up to purchaser to determine fitment prior to purchasing any Aluminess product.
4. Damage. Damage to Aluminess products due to normal wear and tear, including, but not limited to, cosmetic issues and superficial scratches, or structural damage to an Aluminess product in connection with any vehicle collisions or other structural degradation in connection with the use of such vehicle (on road or off road) will not be covered by the Aluminess warranty. Additionally, any product user's misuse, neglect, overloading, improper maintenance or improper installation or repair of any Aluminess products are not covered under the Aluminess warranty.
5. Use of the Products. Aluminess products are designed for off road vehicle use. Installing Aluminess products on a vehicle may exceed the factory designed capabilities of such vehicle and could potentially lead to vehicle damage. Aluminess will not be responsible for any damage caused to a purchaser or user's vehicle or any vehicle accessories caused by the use of any Aluminess products. It is to the sole responsibility of purchaser to inspect and ensure that the intended vehicle and Aluminess products are suitable and compatible for travel on road and off road. No seller nor any manufacturer of Aluminess products will be liable for any loss, damage or injury directly or indirectly arising from the use of any Aluminess products. Before using any Aluminess products, the purchaser or user will determine the suitability of the product(s) for their intended use(s) and the purchaser or user shall assume all responsibility and risk in connection therewith.
6. DISCLAIMER. THE ALUMINESS WARRANTY IS EXPRESSLY MADE IN LIEU OF ANY AND ALL OTHER WARRANTIES, AND EXCEPT FOR THE ALUMINESS WARRANTY SET FORTH HEREIN, ALUMINESS MAKES NO WARRANTY WHATSOEVER WITH RESPECT TO ANY ALUMINESS PRODUCT, INCLUDING ANY WARRANTY OF MERCHANTABILITY AND FITNESS FOR A PARTICULAR PURPOSE, WHETHER EXPRESS OR IMPLIED BY LAW, COURSE OF DEALING, COURSE OF PERFORMANCE, USAGE OF TRADE, OR OTHERWISE.
EXCEPT FOR PURCHASER'S LIMITED REMEDIES SET FORTH HEREIN, IN NO EVENT WILL ALUMINESS BE LIABLE FOR ANY LOST PROFITS, LOST SALES, OR FOR ANY CONSEQUENTIAL, DIRECT, INDIRECT, INCIDENTAL, SPECIAL, EXEMPLARY OR PUNITIVE DAMAGES OR FOR ANY OTHER DAMAGES OF ANY KIND OR NATURE.
7. Compliance. Aluminess cannot guarantee that its products comply with all Federal, State, and/or local laws. Purchaser is advised to review local vehicle codes for compatibility prior to purchase to ensure that the installation and use of any Aluminess products does not violate any applicable laws.
8. Warranty Claim Submission. Purchaser will be responsible for returning any defective product to Aluminess for warranty consideration and purchaser may be responsible for all costs associated with shipping the product to and from Aluminess. Prior to returning any product for warranty, purchaser must contact Aluminess Products Inc. for proper authorization.